

## OPERATOR'S MANUAL 22-Ton Safety Stand – Pin Type

PROD. NO. 032220  
MOD. NO. 868

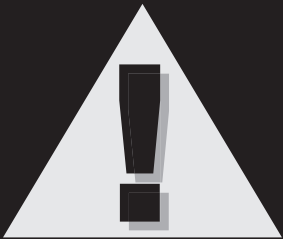

### **WARNING:**

**IMPORTANT: READ THESE INSTRUCTIONS AND ALL WARNINGS PRIOR TO USING THIS EQUIPMENT. UNDERSTAND ALL OPERATING PROCEDURES, SAFETY WARNINGS AND MAINTENANCE REQUIREMENTS. FAILURE TO DO SO COULD CAUSE AN ACCIDENT RESULTING IN SERIOUS OR FATAL INJURY AND/OR PERSONAL PROPERTY DAMAGE.**

A



## WARNING!

The use of portable automotive lifting and support devices is subject to certain hazards that cannot be prevented by mechanical means, but only by the exercise of intelligence, care, and common sense. It is therefore essential to have owners and personnel involved in the use and operation of the equipment who are careful, competent, trained, and qualified in the safe operation of the equipment and its proper use. Examples of hazards are dropping, tipping or slipping of loads caused primarily by improperly secured loads, overloading, off-centered loads, use on other than hard, level surfaces, and using equipment for a purpose for which it was not designed.

### METHODS TO AVOID HAZARDOUS SITUATIONS

- Read, study, understand, and follow all instructions before operating this device.
- Inspect the jack stands before each use. Do not use if damaged, altered, modified, in poor condition, or have loose or missing hardware or parts. Make corrections before using the stands.
- User and bystanders must wear eye protection that meets ANSI Z87.1 and OSHA standards.
- Use as a matched pair only
- Do not use beyond rated capacity. Do not shock load.
- Maximum load capacity per matched pair shall not exceed the rated capacity of the individual stand.
- Use only on a hard, level surface capable of supporting the load.
- Stands are to be used in matched pairs to support one end of a vehicle only. Do not simultaneously support both ends or one side of a vehicle.
- Apply the emergency brake, put the gear shift lever in park or gear if a manual shift transmission, and chock the tires that will not be lifted off the ground.
- Centre load on saddle. Do not use saddle lugs to support the load.
- Check the stands for solid contact with the ground and vehicle.
- Make sure the stand's locking pins are fully engaging the stand on both sides and the support column saddle is making contact with a vehicle support surface that can support the load.
- Ensure both stands are set at same height and locking pawls are fully engaging the support column's teeth.
- **Do not crawl under vehicle when placing/removing stands.**
- Consult the vehicle manufacturer for the proper frame support locations.
- No alterations shall be made to these stands.
- Failure to heed these warnings may result in serious or fatal personal injury and/or property damage.

### CONSEQUENCES OF NOT AVOIDING HAZARDOUS SITUATIONS

Failure to read this manual completely and thoroughly, failure to understand its OPERATING INSTRUCTIONS, SAFETY WARNINGS, MAINTENANCE INSTRUCTIONS and comply with them, and failure to comply with the METHODS TO AVOID HAZARDOUS SITUATIONS could cause accidents resulting in serious or fatal personal injury and/or property damage.



## ASSEMBLY INSTRUCTIONS

1. Install the support column in the stand where the locking holes in the column are facing the locking pin attachment location.
2. Most pin-type jack stands are designed with a support column that can always be removed from the stand; therefore do not attempt to move or lift the stand by pulling up on the column or its saddle.
3. Some stands are equipped with a storage holder for the locking pin. Locking pins connected to the stand by way of a tether or lanyard should not be stored in the stand's support column receiver hole.



## OPERATING INSTRUCTIONS

1. Make sure the work floor is clean and free of debris and obstacles.
2. Chock the vehicle's tires that will not be lifted. Make sure the emergency brake is on and the vehicle's transmission is either in the park mode or gear if a manual transmission.
3. Raise the vehicle to a safe working height and make sure the jack and vehicle setup are stable before positioning the jack stands. **DO NOT CRAWL UNDER THE VEHICLE TO POSITION OR REMOVE STANDS.**
4. Position the jack stands right below the areas of the vehicle to be supported.
5. Lift the support columns as close to the vehicle as possible without the saddles on the columns coming in contact with the vehicle. Make sure the stand's locking pin is fully engaging the stand on both sides. Never use the stand's lower support plate as a load-bearing surface for the locking pin.
6. Slowly and carefully lower the vehicle on the jack stands. Shock loads or loads dropped abruptly on stands can cause premature metal fatigue or even stand failure depending on the weight of the vehicle and the speed of decent that impacts the stands' support columns. **DO NOT CRAWL UNDER THE VEHICLE TO POSITION OR REMOVE STANDS.**
7. When work is completed, raise the vehicle high enough off the stands where the stands can be easily removed.



## PREVENTATIVE MAINTENANCE

1. Always store the jack stands in a well-protected area where they will not be exposed to inclement weather, corrosive vapours, abrasive dust, or any other harmful elements. The stands must be cleaned of water, snow, sand, grit, oil, grease, or other foreign matter before using.
2. Every jack stand owner is responsible for keeping the stand labels clean and readable. Use a mild soap solution to wash external surfaces of the stand. Contact Strongarm for a replacement label if your stand's label is not readable.
3. Inspect the stands before each use. Do not use the stands if any component is cracked, broken, or bent. Do not use the stand if it has loose or missing hardware or components, or is modified in any way. Take corrective action before using the stand again. Premature wearing or damage to components caused by loose or missing hardware is not eligible for warranty consideration.

## 22-TON SAFETY STAND – PIN TYPE

PROD. NO. 032220

MOD. NO. 868

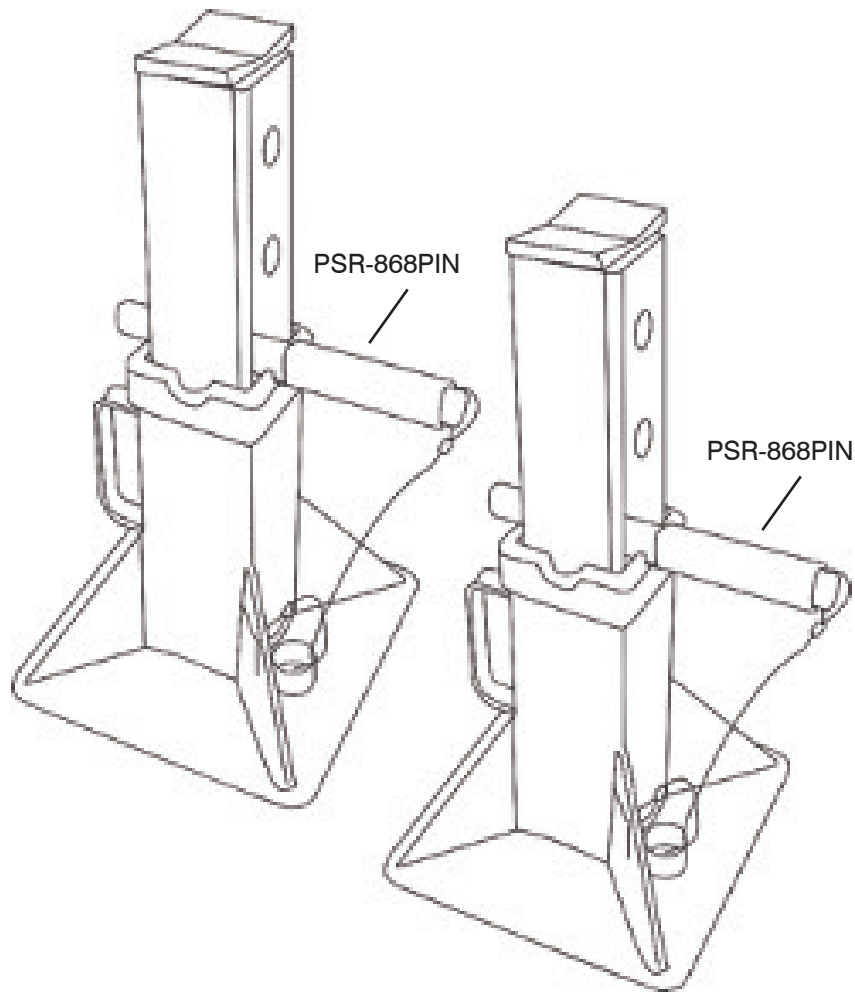

REF	PART NUMBER	DESCRIPTION	REQ
P01	PSR-868PIN	Locking Pin with Wire	1

*Due to safety precautions, only replaceable part is PSR-868PIN, locking pin with wire.*